

400 Hz to DC

- **High Reliability Linear, MTBF 214,600 Hrs.**
- **Military Operating Temperature Range, -55°C to +100°C**
- **249 Standard Models, 12-280 W, Single Output**
- **1.8-240 W, Dual Output**

Specifications

Input:

105 to 125 V rms, 380 to 420 Hz, single phase.

Efficiency:

25% to 60%.

Line Regulation:

Single output within 0.1%, dual output within 0.2% or 10 mV (whichever is greater) for input change of 105 to 125 V ac with load constant.

Load Regulation:

Single output within 0.1%, dual output within 0.2% or 20 mV (whichever is greater) for change from no load to full load with line constant.

Tracking Accuracy (WW Models only):

The negative output will track the positive output to within 1.0% or 100 mV (whichever is greater) for all rated conditions of input voltage, output current, operating temperature, and output voltage adjustment.

Pard (Noise and Ripple):

0.02% or 5 mV rms (whichever is greater), 25 mV peak-to-peak at 25 MHz bandwidth.

Isolation Voltage:

750 V dc input to output and input to case, 200 V dc output to case.

Insulation Resistance:

50 megohms minimum between input and output, input and case, output and case when measured at 50 V dc.

Polarity:

Inputs and outputs are isolated. Either positive or negative side of output may be grounded.

Temperature Range:

Operating -55°C to +100°C baseplate temperature; storage temperature -65°C to +125°C.

Temperature Coefficient:

0.015%/°C from -20°C to +80°C baseplate temperature; 0.03%/°C maximum over entire temperature range.

Input Transient Protection:

In accordance with MIL-STD-704A, Figure 3, Limit 1 (180 V ac for 0.1 second.)

Load Transient Response:

Single output — output voltage returns to regulation limits within 100 microseconds after a 50% step change in load current for models with output of less than

10 amps, and 200 microseconds for models with output current of 10 amps and greater. Dual output — output voltage returns to regulation limits within 200 microseconds after a 50% step change in load current.

Turn-On/Turn-Off Overshoot:

Single output, 0.1% or 20 mV, dual output, 0.2% or 30 mV, (whichever is greater) from nominal voltage set point.

Short Circuit Protection:

Completely protected against short circuit of any duration. Output automatically restores to normal after removal of short.

Overvoltage Protection:

External modules are available for use with all models and internal OVP circuit is available for selected models. Please see Option -1.

Electromagnetic Interference:

Units were designed and built to minimize EMI/EMC emissions, and comply with the requirements of MIL-STD-461A by virtue of their topology, construction, and enclosure.

Reliability:

The MTBF calculated per MIL-HDBK-217C, under operating conditions of 50°C baseplate temperature, maximum operating input voltage and full rated output power is 214,600 hours (W5D10); 242,800 (WW15D0.5) for ground benign and 21,700 hours (W5D10); 24,000 (WW15D0.5) for air inhabited transport environments. Consult factory for other model and environment information.

Environment:

Units are encapsulated and hermetically sealed to meet the environmental requirements of MIL-STD-810C and MIL-E-5400P.



Western Office2727 S. La Cienega Blvd.
Los Angeles, CA 90034
Tel: (213) 202-8820
Fax: (213) 836-1027**Southwest Office**275 W. Campbell Road
Richardson, TX 75080
Tel: (214) 437-0697
Fax: (214) 437-0698**Eastern Office**520 Main Street
Suite 300
Fort Lee, NJ 07024
Tel: (201) 461-4411
Fax: (201) 461-2936**European Office**Ashford, Kent, England
Tel: 0233 623404
Tel: 0233 638132
Fax: 0233 638134**Options**

The following standard options are available on the W and WW Series power supplies. Please refer to the option section of this catalog for detailed information.

Special Connectors:

A military-type hermetically sealed connector is provided as **Option A** in place of our standard header to extend out the top surface. (To order, replace "D" in model number with "A," i.e., W5A2.5.)

Severe Shock, Acceleration and Vibration:

Special encapsulation, **Option E**, enables all units to withstand 60 g's shock, 50 g's acceleration and 30 g's vibration. (To order, add "E" after "D" in model number, i.e., W5DE2.5.)

Remote Turn On/Off:

Option L provides isolated terminals to turn outputs on/off with TTL logic signal. (To order, add "L" after "D" in model number, i.e., W5DL5.0.) This option applies only to models with cases 4D, 9C, 9D and 14C.

Remote Output Adjustment:

With **Option R**, an adjustment potentiometer can be remotely located to adjust the output voltage. (To order, add "R" after "D" in model number, i.e., W5DR5.0.)

Remote Error Sensing:

With **Option Y**, regulator monitors the output voltage directly at the load using extra "sensing" leads and compensates for a dc voltage drop of up to 0.3 volts in the load lead. This option included at no extra charge when **Option A** is ordered. (To order, add "Y" after "D" in model number, i.e., W5DY5.0.)

Enhanced Reliability:

-ER Option provides increased reliability by using higher levels of military-grade components. (To order, add "-ER" following model number, i.e., W5D10-ER.)

Internal Overvoltage Protection:

Option -1 provides an internal crowbar-type OVP. Since this option may result in case size increase, please consult the factory for details. (To order, add "-1" following model number, i.e., W5D20-1.)

abbottWhen
Reliability is
Imperative.**Western Office**
2727 S. La Cienega Blvd.
Los Angeles, CA 90034
Tel: (213) 202-8820
Fax: (213) 836-1027**Southwest Office**
275 W. Campbell Road
Richardson, TX 75080
Tel: (214) 437-0697
Fax: (214) 437-0698**Eastern Office**
520 Main Street
Suite 300
Fort Lee, NJ 07024
Tel: (201) 461-4411
Fax: (201) 461-2936**European Office**
Ashford, Kent, England
Tel: 0233 623404
Tel: 0233 638132
Fax: 0233 638134**W**
Series**64 Popular
Single-Output
Models¹**

Output ² Voltage Range	Output Current (Amps)	Size (See Dwg.)	Weight ³ (Lbs.)	Weight ³ (Kgs.)	Model Number	Output ² Voltage Range	Output Current (Amps)	Size (See Dwg.)	Weight ³ (Lbs.)	Weight ³ (Kgs.)	Model Number	
4.5-5.5	2.5	2E	1.9	0.9	W5D2.5	27-29	1.2	2E	1.9	0.9	W28D1.2	
	5.0	4D	2.7	1.2	W5D5.0		2.5	4D	2.7	1.2	W28D2.5	
	10.0	10B	5.1	2.3	W5D10		5.0	10B	5.1	2.3	W28D5.0	
	15.0	14C	8.9	4.1	W5D15		10.0	14C	8.9	4.1	W28D10	
	20.0	14C	8.9	4.1	W5D20							
5.5-6.5	2.5	2E	1.9	0.9	W6D2.5	29-31	0.6	2E	1.9	0.9	W30D0.6	
	5.0	4D	2.7	1.2	W6D5.0		1.2	4D	2.7	1.2	W30D1.2	
	10.0	10B	5.1	2.3	W6D10		2.5	10B	5.1	2.3	W30D2.5	
	15.0	14C	8.9	4.1	W6D15		5.0	14C	8.9	4.1	W30D5.0	
	20.0	14C	8.9	4.1	W6D20		10.0	14C	8.9	4.1	W30D10	
9.5-10.5	2.5	2E	1.9	0.9	W10D2.5	35-37	0.6	2E	1.9	0.9	W36D0.6	
	5.0	4D	2.7	1.2	W10D5.0		1.2	4D	2.7	1.2	W36D1.2	
	10.0	10B	5.1	2.3	W10D10		2.5	10B	5.1	2.3	W36D2.5	
	15.0	14C	8.9	4.1	W10D15		5.0	14C	8.9	4.1	W36D5.0	
	20.0	14C	8.9	4.1	W10D20							
11-13	2.5	2E	1.9	0.9	W12D2.5	39-41	0.6	2E	1.9	0.9	W40D0.6	
	5.0	4D	2.7	1.2	W12D5.0		1.2	4D	2.7	1.2	W40D1.2	
	10.0	10B	5.1	2.3	W12D10		2.5	10B	5.1	2.3	W40D2.5	
	15.0	14C	8.9	4.1	W12D15		5.0	14C	8.9	4.1	W40D5.0	
	20.0	14C	8.9	4.1	W12D20							
14-16	1.2	2E	1.9	0.9	W15D1.2	47-49	0.6	2E	1.9	0.9	W48D0.6	
	2.5	4D	2.7	1.2	W15D2.5		1.2	4D	2.7	1.2	W48D1.2	
	5.0	10B	5.1	2.3	W15D5.0		2.5	10B	5.1	2.3	W48D2.5	
	10.0	14C	8.9	4.1	W15D10		5.0	14C	8.9	4.1	W48D5.0	
	15.0	14C	8.9	4.1	W15D15							
19-21	1.2	2E	1.9	0.9	W20D1.2	70-80	0.3	2E	1.9	0.9	W75D0.3	
	2.5	4D	2.7	1.2	W20D2.5		0.6	4D	2.7	1.2	W75D0.6	
	5.0	10B	5.1	2.3	W20D5.0		1.2	10B	5.1	2.3	W75D1.2	
	10.0	14C	8.9	4.1	W20D10							
23-25	1.2	2E	1.9	0.9	W24D1.2	90-100	0.3	2E	1.9	0.9	W95D0.3	
	2.5	4D	2.7	1.2	W24D2.5		0.6	4D	2.7	1.2	W95D0.6	
	5.0	10B	5.1	2.3	W24D5.0		1.2	10B	5.1	2.3	W95D1.2	
	10.0	14C	8.9	4.1	W24D10							
25-27	1.2	2E	1.9	0.9	W26D1.2							
	2.5	4D	2.7	1.2	W26D2.5							
	5.0	10B	5.1	2.3	W26D5.0							
	10.0	14C	8.9	4.1	W26D10							

1. 75 other standard W Models are available with single outputs ranging continuously from 5 to 100 V dc and in power levels of approximately 12, 25, 50, 75 and 100 watts. Maximum output current levels are: 0.3, 0.6, 1.2, 2.5, 5.0, 10.0, 15.0 and 20.0 amps. To order an unlisted model,

consult salesman for nearest standard output voltage, and use model numbering system below.

2. Output voltage of single output models is continuously adjustable between the limits shown by means of an externally accessible screwdriver adjustment potentiometer. Adjustment resolution is 35

millivolts for output voltages 5 to 16 V dc, 60 millivolts for outputs 18 to 50 V dc and 90 millivolts for outputs 55 to 95 V dc.

3. Maximum weight, not including options.

**Model Numbering
System**

Product Line Series	Output Voltage Nominal	Header Type	Options	Output Current Maximum Load
W	9	D		10

Western Office
2727 S. La Cienega Blvd.
Los Angeles, CA 90034
Tel: (213) 202-8820
Fax: (213) 836-1027

Southwest Office
275 W. Campbell Road
Richardson, TX 75080
Tel: (214) 437-0697
Fax: (214) 437-0698

Eastern Office
520 Main Street
Suite 300
Fort Lee, NJ 07024
Tel: (201) 461-4411
Fax: (201) 461-2936

European Office
Ashford, Kent, England
Tel: 0233 623404
Tel: 0233 638132
Fax: 0233 638134

70 Popular Dual-Output Models¹

Output ² Voltage Range	Output Current (Amps)	Size (See Dwg.)	Weight ³ (Lbs.)	Weight ³ (Kgs.)	Model Number
±2.75-±3.75	0.3	8B	1.9	0.9	WW3D0.3
	0.5	9C	2.2	1.0	WW3D0.5
	1.0	9C	2.2	1.0	WW3D1.0
	2.0	9D	3.1	1.4	WW3D2.0
	4.0	11D	5.5	2.5	WW3D4.0
±3.75-±4.25	0.3	8B	1.9	0.9	WW4D0.3
	0.5	9C	2.2	1.0	WW4D0.5
	1.0	9C	2.2	1.0	WW4D1.0
	2.0	9D	3.1	1.4	WW4D2.0
	4.0	11D	5.5	2.5	WW4D4.0
±4.5-±5.5	0.3	8B	1.9	0.9	WW5D0.3
	0.5	9C	2.2	1.0	WW5D0.5
	1.0	9C	2.2	1.0	WW5D1.0
	2.0	9D	3.1	1.4	WW5D2.0
	4.0	11D	5.5	2.5	WW5D4.0
±7.5-±8.5	0.3	8B	1.9	0.9	WW8D0.3
	0.5	9C	2.2	1.0	WW8D0.5
	1.0	9C	2.2	1.0	WW8D1.0
	2.0	9D	3.1	1.4	WW8D2.0
	4.0	11D	5.5	2.5	WW8D4.0
±9.5-±10.5	0.3	8B	1.9	0.9	WW10D0.3
	0.5	9C	2.2	1.0	WW10D0.5
	1.0	9C	2.2	1.0	WW10D1.0
	2.0	9D	3.1	1.4	WW10D2.0
	4.0	11D	5.5	2.5	WW10D4.0
±11-±13	0.3	8B	1.9	0.9	WW12D0.3
	0.5	9C	2.2	1.0	WW12D0.5
	1.0	9C	2.2	1.0	WW12D1.0
	2.0	9D	3.1	1.4	WW12D2.0
	4.0	11D	5.5	2.5	WW12D4.0
±14-±16	0.3	8B	1.9	0.9	WW15D0.3
	0.5	9C	2.2	1.0	WW15D0.5
	1.0	9C	2.2	1.0	WW15D1.0
	2.0	9D	3.1	1.4	WW15D2.0
	4.0	11D	5.5	2.5	WW15D4.0

Output ² Voltage Range	Output Current (Amps)	Size (See Dwg.)	Weight ³ (Lbs.)	Weight ³ (Kgs.)	Model Number
±15-±17	0.3	9C	2.2	1.0	WW16D0.3
	0.5	9C	2.2	1.0	WW16D0.5
	1.0	9D	3.1	1.4	WW16D1.0
	2.0	11D	5.5	2.5	WW16D2.0
	4.0	14C	8.0	3.6	WW16D4.0
±17-±19	0.3	9C	2.2	1.0	WW18D0.3
	0.5	9C	2.2	1.0	WW18D0.5
	1.0	9D	3.1	1.4	WW18D1.0
	2.0	11D	5.5	2.5	WW18D2.0
	4.0	14C	8.0	3.6	WW18D4.0
±19-±21	0.3	9C	2.2	1.0	WW20D0.3
	0.5	9C	2.2	1.0	WW20D0.5
	1.0	9D	3.1	1.4	WW20D1.0
	2.0	11D	5.5	2.5	WW20D2.0
	4.0	14C	8.0	3.6	WW20D4.0
±21-±23	0.3	9C	2.2	1.0	WW22D0.3
	0.5	9C	2.2	1.0	WW22D0.5
	1.0	9D	3.1	1.4	WW22D1.0
	2.0	11D	5.5	2.5	WW22D2.0
	4.0	14C	8.0	3.6	WW22D4.0
±23-±25	0.3	9C	2.2	1.0	WW24D0.3
	0.5	9C	2.2	1.0	WW24D0.5
	1.0	9D	3.1	1.4	WW24D1.0
	2.0	11D	5.5	2.5	WW24D2.0
	4.0	14C	8.0	3.6	WW24D4.0
±27-±29	0.3	9C	2.2	1.0	WW28D0.3
	0.5	9C	2.2	1.0	WW28D0.5
	1.0	9D	3.1	1.4	WW28D1.0
	2.0	11D	5.5	2.5	WW28D2.0
	4.0	14C	8.0	3.6	WW28D4.0
±29-±31	0.3	9C	2.2	1.0	WW30D0.3
	0.5	9C	2.2	1.0	WW30D0.5
	1.0	9D	3.1	1.4	WW30D1.0
	2.0	11D	5.5	2.5	WW30D2.0
	4.0	14C	8.0	3.6	WW30D4.0

1. 40 other standard WW Models are available with dual outputs ranging continuously from ±3 V dc to ±30 V dc and maximum output current levels per side of: 0.3, 0.5, 1.0, 2.0 and 4.0 amps. To order, consult salesman.

2. Output voltage of dual output models is continuously adjustable between the limits shown by means of an externally accessible screwdriver adjustment potentiometer. Adjustment resolution is 25 millivolts for output voltages ±3 to

±4.5 V dc, 35 millivolts for outputs ±5 to ±15, and 60 millivolts for outputs ±16 to ±30 V dc.

3. Maximum weight, not including options.

Model Numbering System

Product Line Series	Output Voltage Nominal	Header Type	Options	Output Current Maximum Load
WW	9	D		10

abbott

When Reliability is Imperative.

Western Office
2727 S. La Cienega Blvd.
Los Angeles, CA 90034
Tel: (213) 202-8820
Fax: (213) 836-1027

Southwest Office
275 W. Campbell Road
Richardson, TX 75080
Tel: (214) 437-0697
Fax: (214) 437-0698

Eastern Office
520 Main Street
Suite 300
Fort Lee, NJ 07024
Tel: (201) 461-4411
Fax: (201) 461-2936

European Office
Ashford, Kent, England
Tel: 0233 623404
Tel: 0233 638132
Fax: 0233 638134

Case Drawings

Single-Output

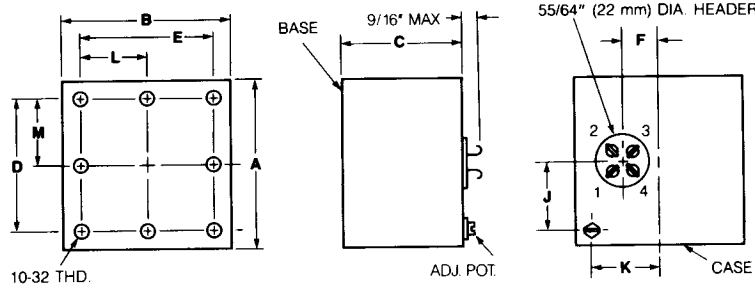

Dual-Output

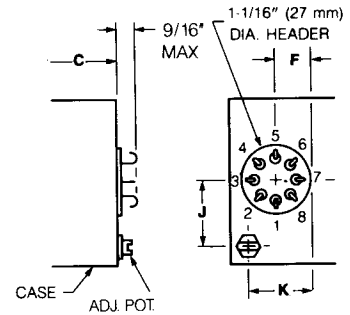

Dimensions

Inches
mm

Case Size	A	B	C	D	E	F	J	K	L	M
2E	2-1/8 54	3-1/4 83	3-1/4 83	1.62 41.2	2.75 69.9	28/32 22	13/16 21	1-3/8 35		
4D	2-1/2 64	3-1/2 89	3-1/2 89	2.00 50.8	3.00 76.2	0 0	1 25	1-1/2 38		
8B	2-5/8 67	3-1/2 89	2-7/8 73	2.12 53.9	3.00 76.2	3/4 19	1-1/16 27	1-1/2 38		
9C	2-1/2 64	4-3/8 111	3-1/8 79	2.00 50.8	3.87 98.3	1 25	1 25	1-15/16 49		
9D	2-5/8 67	4-3/4 121	3-5/8 92	2.12 53.9	4.25 108.0	1 25	1-1/16 27	2-1/8 54		
10B	2-7/8 73	4-1/4 108	4-3/8 111	2.37 60.2	3.75 95.3	1-3/8 35	1-3/16 30	1-7/8 48		
11D	4 102	4-7/8 124	3-7/8 98	3.50 88.9	4.37 111.1	1-3/8 35	1-3/4 44	2-3/16 56		
14C	5-1/2 140	5-1/2 140	3-5/8 92	5.00 127.0	5.00 127.0	1-7/8 48	2-1/2 64	2-1/2 64	2.50 63.5	2.50 63.5

Tolerances: If English unit is a fraction, ± 1/32 inch, (0.8 mm); if English unit is a decimal, ± .015 inch, (0.4 mm).
Material: Base — Aluminum 6061-T6, Case — Steel

Finish: Black flat lacquer per FED-STD-595, Color 37038.
Mounting: 10-32 THD inserts 5/32" minimum depth are provided in baseplate. Steel 10-32 bolts American

Standard, unified national fine series, slotted studs are supplied with each unit. Metric hardware and inserts available as a special order.

Pin Designations

(Standard model, not including options. Consult factory for details.)

Standard W (4-Pin Header)

- 1. AC Input
- 2. AC Input
- 3. +Output
- 4. -Output

Standard WW (8-Pin Header*)

- 1. AC Input
- 2. AC Input
- 3. +Output
- 4. Common Output
- 5. -Output
- 6. Not Used
- 7. Not Used
- 8. Not Used

*1-1/16" (27 mm) diameter

Western Office
 2727 S. La Cienega Blvd.
 Los Angeles, CA 90034
 Tel: (213) 202-8820
 Fax: (213) 836-1027

Southwest Office
 275 W. Campbell Road
 Richardson, TX 75080
 Tel: (214) 437-0697
 Fax: (214) 437-0698

Eastern Office
 520 Main Street
 Suite 300
 Fort Lee, NJ 07024
 Tel: (201) 461-4411
 Fax: (201) 461-2936

European Office
 Ashford, Kent, England
 Tel: 0233 623404
 Tel: 0233 638132
 Fax: 0233 638134

Input Current
 (Typical)
 Amps

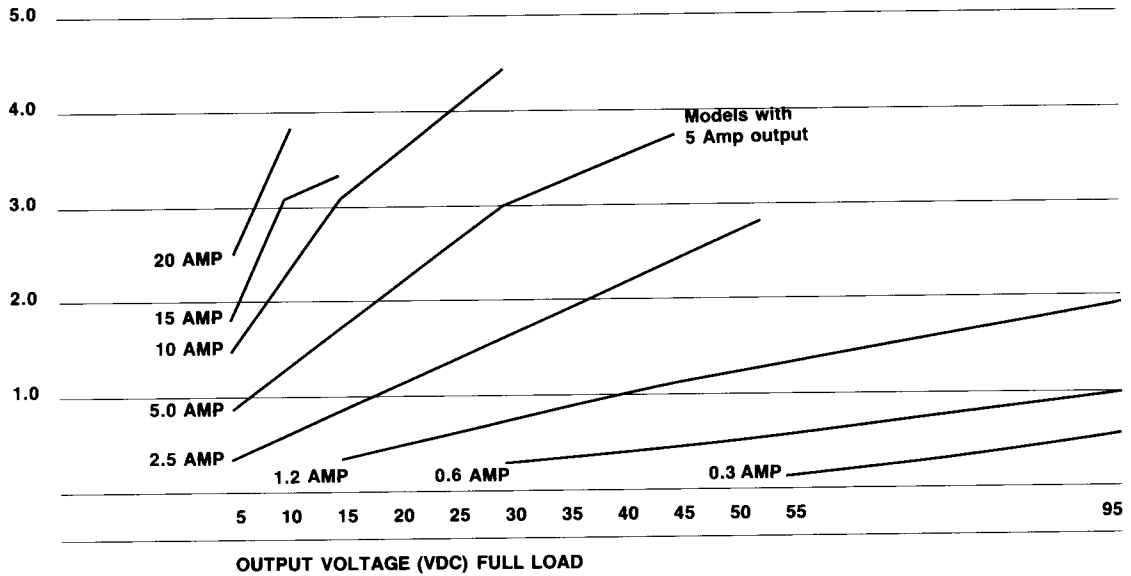

Input Current
 (Typical)
 Amps

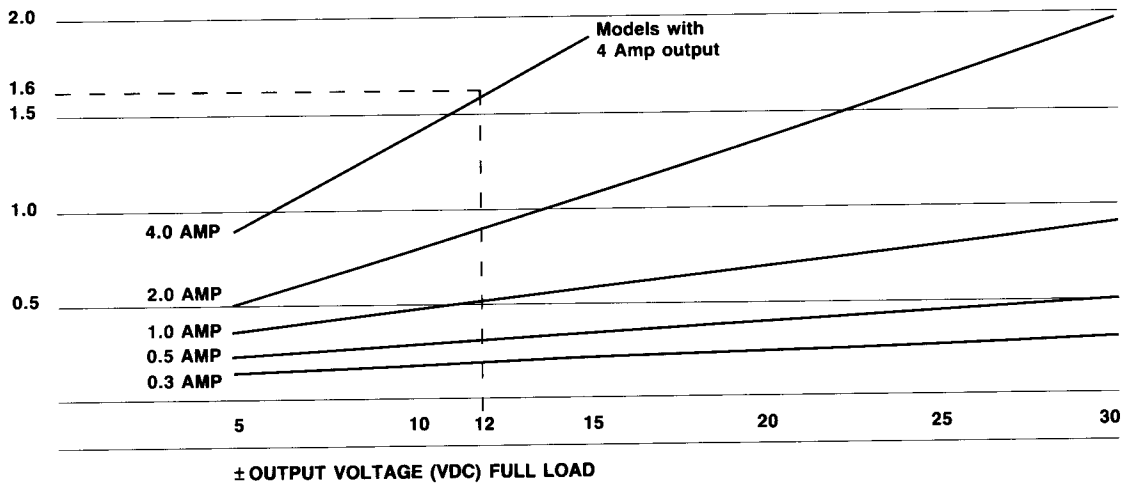

The input current is described by the vertical column of numbers on the left of the chart. The curves or diagonal lines describe the output current of the specific power supply model. The output voltage is described by the horizontal row of numbers on the bottom of the chart.

By locating the intersection of the proper output voltage and the output current, the input current is read from the vertical column on the left.

For example, model WW12D4.0, ±12 volt output and 4.0 amps will require an input current of approximately 1.6 amps at full load as shown.